

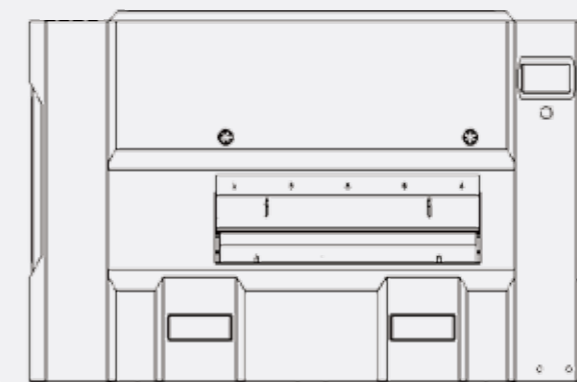

几秒 矫平各种金属板材

专业矫平



广东玛哈特智能科技有限公司
江西玛哈特智能科技有限公司
电话: 0769-86301265 13827206784
邮箱: mark@gddys.com
网址: <https://www.mahatma.com.cn/en>
全国统一服务热线: 400-0898-858

Guangdong Mahatma Intelligent Technology Co., LTD
Jiangxi Mahatma Intelligent Technology Co., LTD
Tel: 0769-86301265 13827206784
E-mail: mark@gddys.com
Web: <https://www.mahatma.com.cn/en>
National unified service hotline: 400-0898-858

关于我们 ABOUT US

玛哈特品牌——系广东（江西）大永圣科技有限公司旗下运营的高端自动化品牌。——致力于研发、生产、销售高精度矫平机以及配套周边设备的高新技术企业。引进德国、瑞士精密矫平/矫直设备技术，并和多家高校、研究所开展产、学、研合作，不断进行技术创新和生产改进，并结合众多金属精密零部件制造企业需求，采用创新的设计思路，先进的制造工艺，研发生产：伺服数控高精度整平机，液压高精度整平机、四（六）重式整平机、自动上下料机械手、机器人、激光整平检测仪、高精度开卷矫平冲压剪切线以及激光切割等全自动生产线。玛哈特集20年行业经验之大成，矫平精度已达到国际最先进水平，多项技术属行业首创！为客户消除材料内应力、恢复及提高零件平面度，为后道的折弯、焊接等工序实现低成本、高效率、高品质的全自动化矫平设备，给广大企业带来了强劲福音。为机厢机柜、汽摩配件、交通、航空航天、钣金加工、建筑行业、医疗技术行业、电力电气、纺织机械、建材、天花幕墙、5G通讯、线路板、电子零件、治夹具、锯片基体等各大行业的知名企业提供解决方案。

Mahatma - is a high - end automation brand operated by Guangdong (Jiangxi) Mahatma Technology Co., Ltd. —— A high-tech enterprise dedicated to R&D, production and sales of high - precision leveling machines and supporting peripheral equipment. Introduce German and Swiss precision leveling / straightening equipment technology , and cooperate with many universities and research institutes in production, learning, and research to continuously carry out technological innovation and production improvement, and combine the needs of many metal precision parts manufacturing enterprises to adopt innovation Design ideas , advanced manufacturing technology , R&D and production : servo CNC high - precision leveling machine , hydraulic high - precision leveling machine , four (six) heavy - duty leveling machine , automatic loading and unloading manipulator , robot , laser leveling detector , High - precision uncoiling , leveling , stamping and shearing line and laser cutting and other automatic production lines. Mahatma has accumulated 20 years of industry experience, the leveling accuracy has reached the most advanced level in the world, and a number of technologies are the first in the industry! Eliminate the internal stress of materials, restore and improve the flatness of parts for customers, and realize low-cost, high - efficiency and high - quality fully automated leveling equipment for subsequent bending , welding and other processes, which has brought a strong gospel to the majority of enterprises. It is used for the cabin cabinets, automobile and motorcycle accessories, transportation, aerospace , sheet metal processing, construction industry, medical technology industry, electric power and electrical, textile machinery, building materials, ceiling curtain walls, 5G communications, circuit boards, electronic parts, fixtures, saw blade substrates, etc. Well-known companies in the industry provide solutions.





随着江西抚州产业园的正式投产以及玛哈特昆山、青岛、宁波分公司的建立，公司在品牌、战略、研发，产能，服务上将有更大的提升，并陆续在青岛、沈阳、宁波、成都、西安、长沙、武汉、哈尔滨、石家庄、厦门等全国各地成立分公司建立服务基地。

持续创新、精益求精，不断提升品质、效益和品牌影响力，大力推进品牌国际化战略，培育全球技术竞争的新优势，着力打造享誉国际品牌的中国工业品牌企业，不断提升企业品牌价值和“中国制造”的整体形象。

玛哈特集二十年的产品沉淀和国内外专家及高等院校的有力结合，掌握了该产品工艺的核心技术，开创了整平机的新时代。作为公司理念，立志成为国内外品牌最专业的金属精整处理设备生产商，为全球广大制造企业提供高性价比的设备与服务!!!

With the Commencement and operation of Jiangxi Fuzhou Industrial Park, and the establishment of Mahat's Kunshan, Qingdao, and Ningbo branches, the company will have greater improvements in brand, strategy, development, production capacity, and service. Ningbo, Chengdu, Xi'an, Changsha, Wuhan, Harbin, Shijiazhuang, Xiamen and other parts of the country have established branches to establish service bases.

Continue to innovate, strive for excellence, continuously improve quality, efficiency and brand influence, vigorously promote brand internationalization strategies, cultivate new advantages in global technological competition, strive to build a Chinese industrial brand with international brands, and continuously improve brand value of enterprise and "Made in China".

Mahatma has accumulated 20 years of product precipitation and the powerful combination of domestic and foreign experts, colleges and universities, mastered the main technology of the product process, and created a new era of leveling machines. As the company's philosophy, we are determined to become the most professional manufacturer of metal finishing equipment for domestic and foreign brands, and provide cost-effective equipment and services for global manufacturing companies!!!

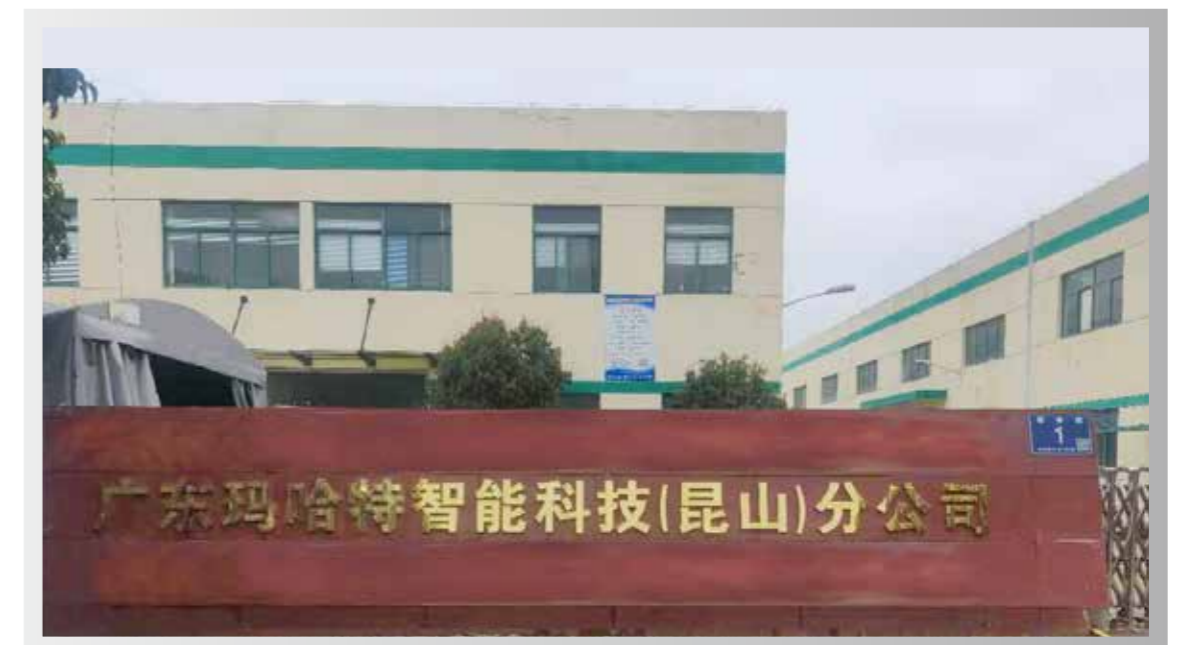

企业文化
CORPORATE
CULTURE

企业愿景：

国际矫平行业领先品牌

企业使命：

专业替代进口 打造民族品牌

企业精神：

渴望 信念 意志 行动

企业口号：

玛哈特矫平机—矫平天下不平事

企业宗旨：

重合同、守信誉、顾客至上

服务宗旨：

从客户出发、为客户着想、对客户负责、让客户满意

Corporate vision:

Leading brand in the international leveling industry

Our Mission:

Professional substitution of imports, creating a national brand

Enterprise spirit:

Desire, Faith, Will, Action

Enterprise slogan:

Mahatma leveling machine-let everything go back to right way

Company purpose:

Attention to contract, stick to credibility, customer first

Service purposes:

Focusing on needs of customer, thinking about the customer, being responsible for the customer, and satisfying the customer

精益求精、持续创新, 专注品质、铸就品牌

Strive for excellence, continuous innovation, focus on quality, strengthen brand



数控精密矫平机

CNC HIGH PRECISION LEVELING MACHINE





金属材料在较大弹性弯曲条件下，不管其原始弯曲程度有多大区别，数控精密矫平机利用材料的“包辛格效应”对板材进行多次反复弯曲，逐渐减小压弯挠度，使多种原始曲率逐步变为单一曲率，并最终将其矫平，达到工艺要求的平整精度。

数控矫平机在工业上已广泛应用，具有技术先进、矫平精度高、工艺范围广、自动化程度高、高强度下工作可靠稳定等等特点，在轧辊整平过程中，金属板材经过一系列的交替折弯，通过电机和PLC控制对每根整平滚筒的下压量的精确控制，消除内应力，从根本上解决了因板材各部位应力不一样而产生的整平效果不理想情况，从而实现了高精度的整平。

Under the condition of large elastoplastic bending, the CNC precision leveler uses the "Bauschinger effect" of the material to bend the plate repeatedly, and gradually reduces the bending deflection, no matter how different the original bending degree is. The multiple original curvatures gradually become a single curvature, and they are finally leveled to achieve the leveling accuracy required by the process.

CNC leveling machines have been widely used in industry. They have the characteristics of advanced technology, high leveling accuracy, wide process range, high degree of automation, reliable and stable work under high strength, etc. During the roll leveling process, the sheet metal passes through a series of Alternate bending, the precise control of the pressing amount of each leveling drum through the motor and PLC control, eliminates the internal stress, and fundamentally solves the unsatisfactory leveling effect caused by the different stresses in each part of the sheet. Aim to achieve high-precision leveling.

数控高精密矫平机设备功能

CNC high-precision leveling machine equipment functions

与其他整平方法相比，该机控制系统具有存储、调用、编辑工艺及设备参数功能并具有误操作识别预警功能。使用时，在操作台上，可以根据板厚、板宽等参数或数据库已有参数设定进、出口压下量，实现工作辊出、入间隙等的电动调整，并可手工调整和修正。

Compared with other leveling methods, the machine's control system has the functions of storing, recalling, editing process and equipment parameters, and it has the function of identifying and early warning of misoperation. When it work, on the operating table, the inlet and outlet reductions can be set according to parameters such as plate thickness and plate width or the existing parameters in the database to realize the electric adjustment of the work roll out and in-out gap, and can be manually adjusted and corrected.



本机采用日本松下PLC控制器，并由台达变频器控制运转速度，机器所有动作均由操作台集中控制，触摸式人机界面显示屏，操作面板简单易懂，在机台进出口四个显眼位置安装紧急开关，以确保操作安全！并配有数显显示位移量，操作非常简便、迅速。只需几秒钟，即可矫平通常需长时间手工整平的高精度复杂的五金件。

This machine adopts the Japanese Panasonic PLC controller, and the Delta frequency converter controls the running speed. All the machine actions are controlled by the operation console. The touch-sensitive man-machine interface display screen and the operation panel are simple and easy to understand. Emergency switches are installed at the four conspicuous positions of the exit to ensure safe operation! It is also equipped with a digital display to display the displacement amount, which is very simple and fast. It only takes a few seconds to level high-precision and complex hardware that usually takes a long time to level by hand.

控制系统
CONTROL SYSTEM

数控矫平机是为机厢机柜、汽摩配件、交通、航空航天、钣金加工、建筑行业、医疗技术行业、电力电气、纺织机械、电梯、通讯等各大行业的知名企业提供解决方案。对工业结构件的垂直度、平行度及外观和精度起到至关重要的作用！

CNC leveling machine is to provide solutions for well-known enterprises in various major industries such as machine cabinets, automobile and motorcycle accessories, transportation, aerospace, sheet metal processing, construction industry, medical technology industry, electric power and electrical, textile machinery, elevators, and communications. It plays a vital role in the verticality, parallelism, appearance and accuracy of industrial structural parts!

适用范围
SCOPES OF APPLICATION



全自动数控矫平机带流水线外观图
Appearance drawing of automatic CNC leveling machine with assembly line



滚轮快速清洁装置
Roller quick cleaning device



快速换滚装置
Quick roll change device

客户选配如下:

Customer options are as follows:

1、自动进出料流水线 1. Automatic feeding and discharging assembly line	2、四/六重式辊以及辊轴数量 2. The number of four/six-fold rollers and roller shafts
3、滚轮快速清洁装置 3. Roller quick cleaning device	4、自动上下料机械手、机器人 4. Automatic loading and unloading manipulators, robots
5、在线厚度检测 5. Online thickness detection	6、翘曲平面度自动检测仪 6. Automatic detector for warpage and flatness

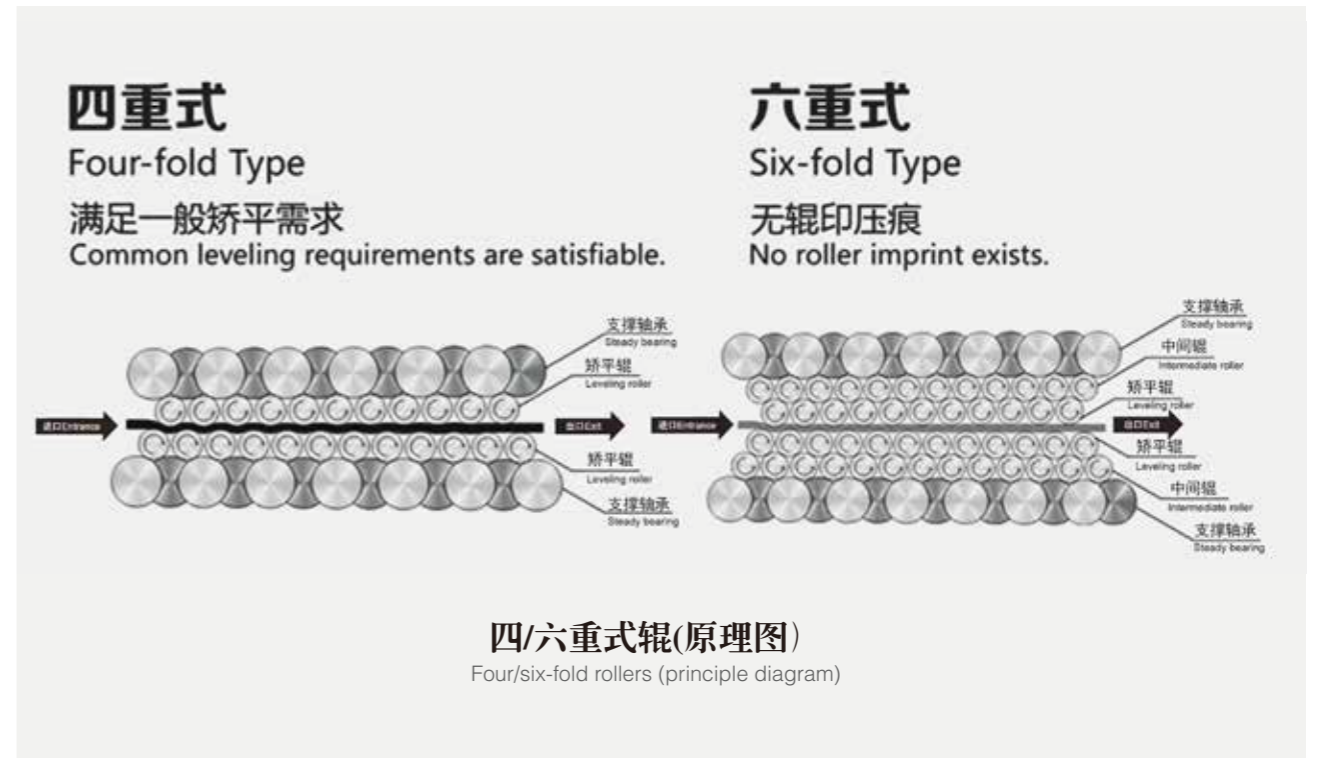

四重式性能与特点

Performances and features of Four-fold type

校平辊受力分布均匀
结构刚性好, 变形小, 校平精度高
校平板表面质量好, 传动平稳, 噪音低
适用于碳钢板, 不锈钢板

Uniform force distribution of leveling rollers
Good structure rigidity, small deformation, high leveling accuracy
The surface quality of leveling plate is good, the transmission is stable, and the noise is low
Suitable for carbon steel plate and stainless steel plate

六重式性能与特点

Performances and features of Six-fold type

校平辊受力分布均匀
结构刚性好, 变形小, 校平精度高
校平板表面质量好, 传动平稳, 噪音低, 无辊压痕
单面分三层辊: 支撑轴承, 中间辊, 矫平辊
适用于碳钢板, 不锈钢板, 铝板

Uniform force distribution of leveling rollers
Good structure rigidity, small deformation, high leveling accuracy
The surface quality of the leveling plate is good, the transmission is stable, the noise is low, and there is no roller indentation
Single-sided three-layer roller: support bearing, intermediate roller, leveling roller
Suitable for carbon steel plate, stainless steel plate, aluminum plate

量产机型

MHT10-150-25

Production models
MHT10-150-25

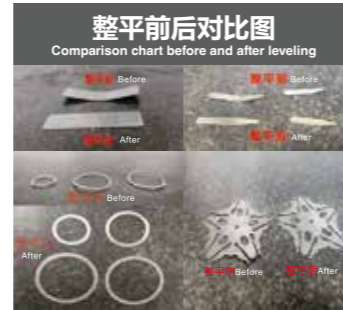

MHT10系列(厚度: 0.03-0.6mm)

MHT10 series(Thickness: 0.03-0.6mm)

机型 Model	MHT10-100-25	MHT10-150-25	MHT10-200-25	MHT10-300-25
宽度 Width	0-100mm	0-150mm	0-200mm	0-300mm
辊径 Roll diameter	10	10	10	10
额定厚度 Rated thickness	0.03-0.6mm	0.03-0.6mm	0.03-0.6mm	0.03-0.6mm
最大厚度 Maximum thickness	1.0mm	1.0mm	1.0mm	1.0mm
辊数 Number of rolls	25	25	25	25
最短工件 Shortest part	20	20	20	20
矫平速度 Leveling speed	0-10m/min	0-10m/min	0-10m/min	0-10m/min
电压 Voltage	AC三相380VAC 3-phase 380V	AC三相380VAC 3-phase 380V	AC三相380VAC 3-phase 380V	AC三相380VAC 3-phase 380V

选配
Optional

1、上下料取料机机械手2、上下料关节机器人3、自动检测平台4、进出料流水线5、自动堆料升降台6、滚轮快速清洁装置
1. Loading and unloading and reclaiming manipulators 2. Loading and unloading joint robots 3. Automatic detection platform
4. Inlet and outflow assembly line 5. Automatic stacking lifting platform 6. Roller quick cleaning device

更大、特殊尺寸、更快速度可按需求订制
Larger, special size, faster speed can be customized according to demand

量产机型

MHT15-200-25

Production models
MHT15-200-25



MHT15系列(厚度: 0.08-1.0mm)

MHT15 series(Thickness: 0.08-1.0mm)

机型 Model	MHT15-200-25	MHT15-300-25	MHT15-400-25	MHT15-600-25
宽度 Width	0-200mm	0-300mm	0-400mm	0-600mm
辊径 Roll diameter	15	15	15	15
额定厚度 Rated thickness	0.08-1.0mm	0.08-1.0mm	0.08-1.0mm	0.08-1.0mm
最大厚度 Maximum thickness	2.0mm	2.0mm	2.0mm	2.0mm
辊数 Number of rolls	25	25	25	25
最短工件 Shortest part	30	30	30	30
矫平速度 Leveling speed	0-10m/min	0-10m/min	0-10m/min	0-10m/min
电压 Voltage	AC三相380VAC 3-phase 380V	AC三相380VAC 3-phase 380V	AC三相380VAC 3-phase 380V	AC三相380VAC 3-phase 380V

选配
Optional

1、上下料取料机机械手2、上下料关节机器人3、自动检测平台4、进出料流水线5、自动堆料升降台6、滚轮快速清洁装置
1. Loading and unloading and reclaiming manipulators 2. Loading and unloading joint robots 3. Automatic detection platform
4. Inlet and outflow assembly line 5. Automatic stacking lifting platform 6. Roller quick cleaning device

更大、特殊尺寸、更快速度可按需求订制
Larger, special size, faster speed can be customized according to demand

量产机型
MHT20-400-23
Production models
MHT20-400-23



MHT20系列(厚度: 0.3-1.2mm)

MHT20 series(Thickness: 0.3-1.2mm)

机型 Model	MHT20-400-23	MHT20-600-23	MHT20-800-23
宽度 Width	0-200mm	0-400mm	0-600mm
辊径 Roll diameter	20	20	20
额定厚度 Rated thickness	0.3-1.2mm	0.3-1.2mm	0.3-1.2mm
最大厚度 Maximum thickness	3.0mm	3.0mm	3.0mm
辊数 Number of rolls	23	23	23
最短工件 Shortest part	40	40	40
矫平速度 Leveling speed	0-10m/min	0-10m/min	0-10m/min
电压 Voltage	AC三相380VAC 3-phase 380V	AC三相380VAC 3-phase 380V	AC三相380VAC 3-phase 380V
选配 Optional	1、上下料取料机机械手2、上下料关节机器人3、自动检测平台4、进出料流水线5、自动堆料升降台6、滚轮快速清洁装置 1. Loading and unloading and reclaiming manipulators 2. Loading and unloading joint robots 3. Automatic detection platform 4. Inlet and outflow assembly line 5. Automatic stacking lifting platform 6. Roller quick cleaning device		
更大、特殊尺寸、更快速度可按需求订制 Larger, special size, faster speed can be customized according to demand			

量产机型
MHT30-400-23
MHT30-1300-23
Production models
MHT30-400-23
MHT30-1300-23

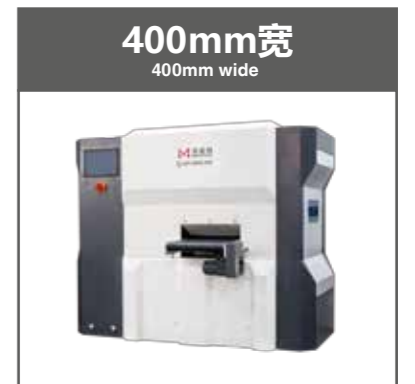
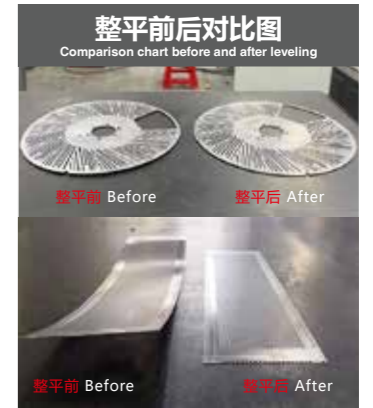

MHT30系列(厚度: 0.5-2.0mm)

MHT30 series(Thickness: 0.5-2.0mm)

机型 Model	MHT30-400-23	MHT30-800-23	MHT30-1300-23	MHT30-1600-23
宽度 Width	0-400mm	0-800mm	0-1300mm	0-1600mm
辊径 Roll diameter	30	30	30	30
额定厚度 Rated thickness	0.5-2.0mm	0.5-2.0mm	0.5-2.0mm	0.5-2.0mm
最大厚度 Maximum thickness	4.0mm	4.0mm	4.0mm	4.0mm
辊数 Number of rolls	23	23	23	23
最短工件 Shortest part	60	60	60	60
矫平速度 Leveling speed	0-10m/min	0-10m/min	0-10m/min	0-10m/min
电压 Voltage	AC三相380VAC 3-phase 380V	AC三相380VAC 3-phase 380V	AC三相380VAC 3-phase 380V	AC三相380VAC 3-phase 380V
选配 Optional	1、上下料取料机机械手2、上下料关节机器人3、自动检测平台4、进出料流水线5、自动堆料升降台6、滚轮快速清洁装置 1. Loading and unloading and reclaiming manipulators 2. Loading and unloading joint robots 3. Automatic detection platform 4. Inlet and outflow assembly line 5. Automatic stacking lifting platform 6. Roller quick cleaning device			
更大、特殊尺寸、更快速度可按需求订制 Larger, special size, faster speed can be customized according to demand				



量产机型
MHT40-400-21
MHT40-1300-21
Production models
MHT40-400-21
MHT40-1300-21

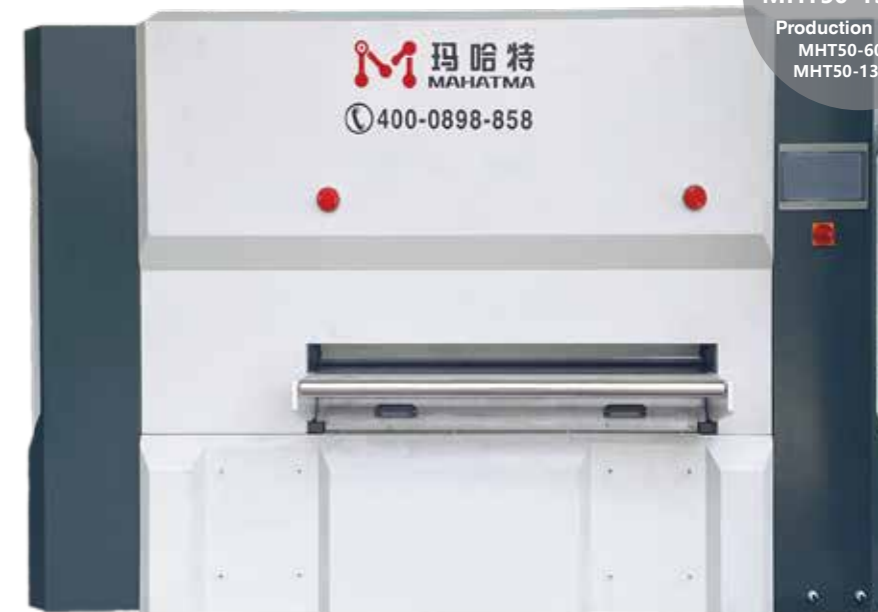
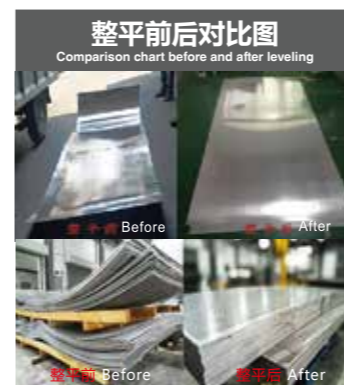

量产机型
MHT50-600-19
MHT50-1300-19
Production models
MHT50-600-19
MHT50-1300-19

MHT40系列(厚度: 0.6-3.0mm)

MHT40 series(Thickness: 0.6-3.0mm)

机型 Model	MHT40-400-21	MHT40-800-21	MHT40-1300-21	MHT40-1600-21	MHT40-2100-21
宽度 Width	0-400mm	0-800mm	0-1300mm	0-1600mm	0-2100mm
辊径 Roll diameter	40	40	40	40	40
额定厚度 Rated thickness	0.6-3.0mm	0.6-3.0mm	0.6-3.0mm	0.6-3.0mm	0.6-3.0mm
最大厚度 Maximum thickness	6.0mm	6.0mm	6.0mm	6.0mm	6.0mm
辊数 Number of rolls	21	21	21	21	21
最短工件 Shortest part	70	70	70	70	70
矫平速度 Leveling speed	0-10m/min	0-10m/min	0-10m/min	0-10m/min	0-10m/min
电压 Voltage	AC三相380VAC 3-phase 380V	AC三相380VAC 3-phase 380V	AC三相380VAC 3-phase 380V	AC三相380VAC 3-phase 380V	AC三相380VAC 3-phase 380V

选配
Optional
1、上下料取料机械手2、上下料关节机器人3、自动检测平台4、进出料流水线5、自动堆料升降台6、滚轮快速清洁装置
1. Loading and unloading and reclaiming manipulators 2. Loading and unloading joint robots 3. Automatic detection platform
4. Inlet and outflow assembly line 5. Automatic stacking lifting platform 6. Roller quick cleaning device

更大、特殊尺寸、更快速度可按需求订制
Larger, special size, faster speed can be customized according to demand

MHT50系列(厚度: 0.8-4.0mm)

MHT50 series(Thickness: 0.8-4.0mm)

机型 Model	MHT50-400-19	MHT50-600-19	MHT50-800-19	MHT50-1000-19	MHT50-1300-19	MHT50-1600-19	MHT50-2100-19
宽度 Width	0-400mm	0-600mm	0-800mm	0-1000mm	0-1300mm	0-1600mm	0-2100mm
辊径 Roll diameter	50	50	50	50	50	50	50
额定厚度 Rated thickness	0.8-4.0mm	0.8-4.0mm	0.8-4.0mm	0.8-4.0mm	0.8-4.0mm	0.8-4.0mm	0.8-4.0mm
最大厚度 Maximum thickness	8.0mm	8.0mm	8.0mm	8.0mm	8.0mm	8.0mm	8.0mm
辊数 Number of rolls	19	19	19	19	19	19	19
最短工件 Shortest part	90	90	90	90	90	90	90
矫平速度 Leveling speed	0-10m/min	0-10m/min	0-10m/min	0-10m/min	0-10m/min	0-10m/min	0-10m/min
电压 Voltage	AC三相380VAC 3-phase 380V	AC三相380VAC 3-phase 380V	AC三相380VAC 3-phase 380V	AC三相380VAC 3-phase 380V	AC三相380VAC 3-phase 380V	AC三相380VAC 3-phase 380V	AC三相380VAC 3-phase 380V

选配
Optional
1、上下料取料机械手2、上下料关节机器人3、自动检测平台4、进出料流水线5、自动堆料升降台6、滚轮快速清洁装置
1. Loading and unloading and reclaiming manipulators 2. Loading and unloading joint robots 3. Automatic detection platform
4. Inlet and outflow assembly line 5. Automatic stacking lifting platform 6. Roller quick cleaning device

更大、特殊尺寸、更快速度可按需求订制
Larger, special size, faster speed can be customized according to demand



MHT60系列(厚度: 1.0-6.0mm)

MHT60 series(Thickness: 1.0-6.0mm)

机型 Model	MHT60-400-19	MHT60-600-19	MHT60-1000-19	MHT60-1300-19	MHT60-1600-19	MHT60-2100-19
宽度 Width	0-400mm	0-600mm	0-1000mm	0-1300mm	0-1600mm	0-2100mm
辊径 Roll diameter	60	60	60	60	60	60
额定厚度 Rated thickness	1.0-6.0mm	1.0-6.0mm	1.0-6.0mm	1.0-6.0mm	1.0-6.0mm	1.0-6.0mm
最大厚度 Maximum thickness	12mm	12mm	12mm	12mm	12mm	12mm
辊数 Number of rolls	19	19	19	19	19	19
最短工件 Shortest part	100	100	100	100	100	100
矫平速度 Leveling speed	0-10m/min	0-10m/min	0-10m/min	0-10m/min	0-10m/min	0-10m/min
电压 Voltage	AC三相380VAC 3-phase 380V	AC三相380VAC 3-phase 380V	AC三相380VAC 3-phase 380V	AC三相380VAC 3-phase 380V	AC三相380VAC 3-phase 380V	AC三相380VAC 3-phase 380V

选配
Optional 1、上下料取料机械手2、上下料关节机器人3、自动检测平台4、进出料流水线5、自动堆料升降台6、滚轮快速清洁装置
1. Loading and unloading and reclaiming manipulators 2. Loading and unloading joint robots 3. Automatic detection platform 4. Inlet and outflow assembly line 5. Automatic stacking lifting platform 6. Roller quick cleaning device

更大、特殊尺寸、更快速度可按需求订制
Larger, special size, faster speed can be customized according to demand

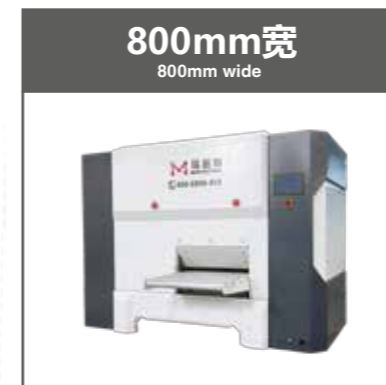

MHT80系列(厚度: 2.0-8.0mm)

MHT80 series(Thickness: 2.0-8.0mm)

机型 Model	MHT80-400-19	MHT80-800-19	MHT80-1300-19	MHT80-1600-19	MHT80-2100-19	MHT80-2600-19
宽度 Width	0-400mm	0-800mm	0-1300mm	0-1600mm	0-2100mm	0-2600mm
辊径 Roll diameter	80	80	80	80	80	80
额定厚度 Rated thickness	2.0-8.0mm	2.0-8.0mm	2.0-8.0mm	2.0-8.0mm	2.0-8.0mm	2.0-8.0mm
最大厚度 Maximum thickness	16.0mm	16.0mm	16.0mm	16.0mm	16.0mm	16.0mm
辊数 Number of rolls	19	19	19	19	19	19
最短工件 Shortest part	130	130	130	130	130	130
矫平速度 Leveling speed	0-10m/min	0-10m/min	0-10m/min	0-10m/min	0-10m/min	0-10m/min
电压 Voltage	AC三相380VAC 3-phase 380V	AC三相380VAC 3-phase 380V	AC三相380VAC 3-phase 380V	AC三相380VAC 3-phase 380V	AC三相380VAC 3-phase 380V	AC三相380VAC 3-phase 380V

选配
Optional 1、上下料取料机械手2、上下料关节机器人3、自动检测平台4、进出料流水线5、自动堆料升降台6、滚轮快速清洁装置
1. Loading and unloading and reclaiming manipulators 2. Loading and unloading joint robots 3. Automatic detection platform 4. Inlet and outflow assembly line 5. Automatic stacking lifting platform 6. Roller quick cleaning device

更大、特殊尺寸、更快速度可按需求订制
Larger, special size, faster speed can be customized according to demand

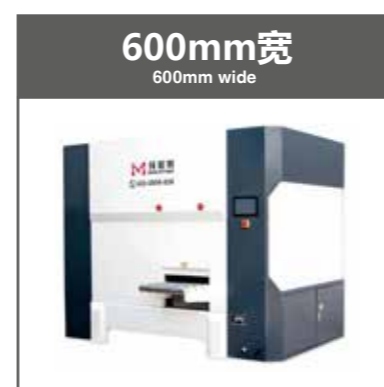
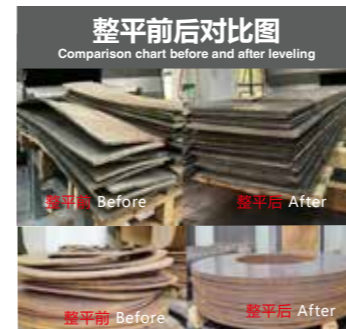
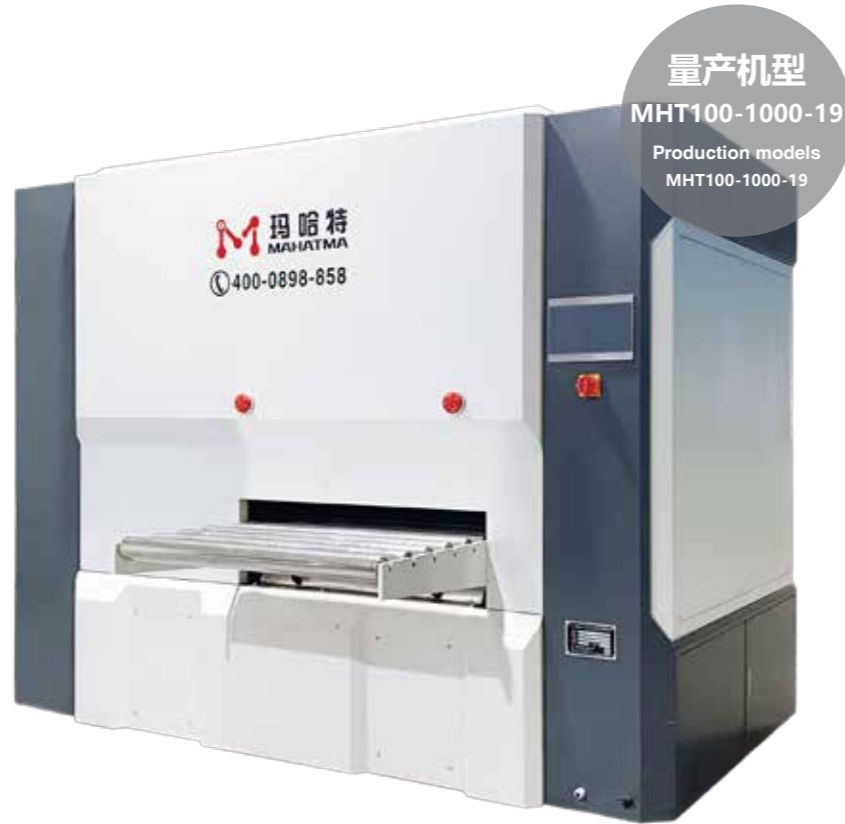
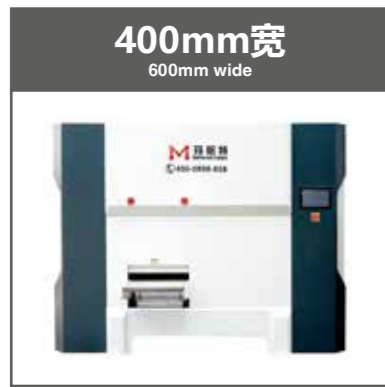
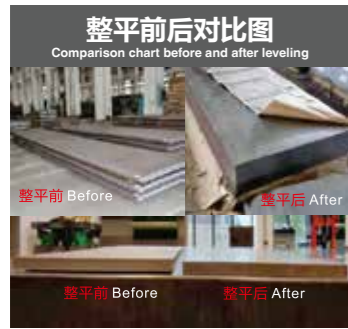

MHT100系列(厚度: 3.0-12.0mm)

MHT100 series(Thickness: 3.0-12.0mm)

机型 Model	MHT100-400-19	MHT100-800-19	MHT100-1000-19	MHT100-1600-19	MHT100-2100-19	MHT100-2600-19
宽度 Width	0-400mm	0-800mm	0-1000mm	0-1600mm	0-2100mm	0-2600mm
辊径 Roll diameter	100	100	100	100	100	100
额定厚度 Rated thickness	3.0-12.0mm	3.0-12.0mm	3.0-12.0mm	3.0-12.0mm	3.0-12.0mm	3.0-12.0mm
最大厚度 Maximum thickness	20.0mm	20.0mm	20.0mm	20.0mm	20.0mm	20.0mm
辊数 Number of rolls	19	19	19	19	19	19
最短工件 Shortest part	160	160	160	160	160	160
矫平速度 Leveling speed	0-10m/min	0-10m/min	0-10m/min	0-10m/min	0-10m/min	0-10m/min
电压 Voltage	AC三相380VAC 3-phase 380V	AC三相380VAC 3-phase 380V	AC三相380VAC 3-phase 380V	AC三相380VAC 3-phase 380V	AC三相380VAC 3-phase 380V	AC三相380VAC 3-phase 380V

选配
Optional
1、上下料取料机2、上下料关节机器人3、自动检测平台4、进出料流水线5、自动堆料升降台6、滚轮快速清洁装置
1. Loading and unloading and reclaiming manipulators 2. Loading and unloading joint robots 3. Automatic detection platform
4. Inlet and outflow assembly line 5. Automatic stacking lifting platform 6. Roller quick cleaning device

更大、特殊尺寸、更快速度可按需求订制
Larger, special size, faster speed can be customized according to demand

MHT120系列(厚度: 4.0-16.0mm)

MHT120 series(Thickness: 4.0-16.0mm)

机型 Model	MHT120-400-19	MHT120-800-19	MHT120-1300-19	MHT120-1600-19	MHT120-2100-19	MHT120-2600-19
宽度 Width	0-400mm	0-800mm	0-1300mm	0-1600mm	0-2100mm	0-2600mm
辊径 Roll diameter	120	120	120	120	120	120
额定厚度 Rated thickness	4.0-16.0mm	4.0-16.0mm	4.0-16.0mm	4.0-16.0mm	4.0-16.0mm	4.0-16.0mm
最大厚度 Maximum thickness	25.0mm	25.0mm	25.0mm	25.0mm	25.0mm	25.0mm
辊数 Number of rolls	19	19	19	19	19	19
最短工件 Shortest part	190	190	190	190	190	190
矫平速度 Leveling speed	0-10m/min	0-10m/min	0-10m/min	0-10m/min	0-10m/min	0-10m/min
电压 Voltage	AC三相380VAC 3-phase 380V	AC三相380VAC 3-phase 380V	AC三相380VAC 3-phase 380V	AC三相380VAC 3-phase 380V	AC三相380VAC 3-phase 380V	AC三相380VAC 3-phase 380V

选配
Optional
1、上下料取料机2、上下料关节机器人3、自动检测平台4、进出料流水线5、自动堆料升降台6、滚轮快速清洁装置
1. Loading and unloading and reclaiming manipulators 2. Loading and unloading joint robots 3. Automatic detection platform
4. Inlet and outflow assembly line 5. Automatic stacking lifting platform 6. Roller quick cleaning device

更大、特殊尺寸、更快速度可按需求订制
Larger, special size, faster speed can be customized according to demand

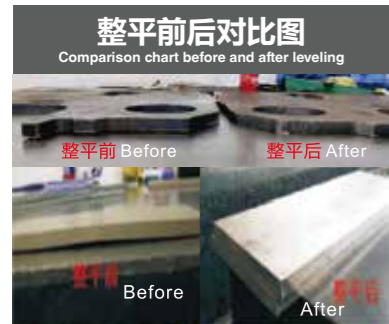

量产机型
MHT150-800
MHT150-1600
Production models
MHT150-800
MHT150-1600

MHT150系列(厚度: 6.0-25.0mm)

MHT150 series(Thickness: 6.0-25.0mm)

机型 Model	MHT150-400	MHT150-800	MHT150-1300	MHT150-1600	MHT150-2100	MHT150-2600
宽度 Width	0-400mm	0-800mm	0-1300mm	0-1600mm	0-2100mm	0-2600mm
辊径 Roll diameter	150	150	150	150	150	150
额定厚度 Rated thickness	6.0-25.0mm	6.0-25.0mm	6.0-25.0mm	6.0-25.0mm	6.0-25.0mm	6.0-25.0mm
最大厚度 Maximum thickness	30.0mm	30.0mm	30.0mm	30.0mm	30.0mm	30.0mm
辊数 Number of rolls	15/19	15/19	15/19	15/19	15/19	15/19
最短工件 Shortest part	240	240	240	240	240	240
矫平速度 Leveling speed	0-10m/min	0-10m/min	0-10m/min	0-10m/min	0-10m/min	0-10m/min
电压 Voltage	AC三相380VAC 3-phase 380V	AC三相380VAC 3-phase 380V	AC三相380VAC 3-phase 380V	AC三相380VAC 3-phase 380V	AC三相380VAC 3-phase 380V	AC三相380VAC 3-phase 380V

选配
Optional
1、上下料取料机机械手2、上下料关节机器人3、自动检测平台4、进出料流水线5、自动堆料升降台6、滚轮快速清洁装置
1. Loading and unloading and reclaiming manipulators 2. Loading and unloading joint robots 3. Automatic detection platform
4. Inlet and outflow assembly line 5. Automatic stacking lifting platform 6. Roller quick cleaning device

更大、特殊尺寸、更快速度可按需求订制
Larger, special size, faster speed can be customized according to demand



量产机型
MHT200-1300
Production models
MHT200-1300

MHT200系列(厚度: 8.0-30.0mm)

MHT200 series(Thickness: 8.0-30.0mm)

机型 Model	MHT200-400	MHT200-800	MHT200-1300	MHT200-1600	MHT200-2100	MHT200-2600
宽度 Width	0-400mm	0-800mm	0-1300mm	0-1600mm	0-2100mm	0-2600mm
辊径 Roll diameter	200	200	200	200	200	200
额定厚度 Rated thickness	8.0-30.0mm	8.0-30.0mm	8.0-30.0mm	8.0-30.0mm	8.0-30.0mm	8.0-30.0mm
最大厚度 Maximum thickness	40.0mm	40.0mm	40.0mm	40.0mm	40.0mm	40.0mm
辊数 Number of rolls	15/19	15/19	15/19	15/19	15/19	15/19
最短工件 Shortest part	310	310	310	310	310	310
矫平速度 Leveling speed	0-10m/min	0-10m/min	0-10m/min	0-10m/min	0-10m/min	0-10m/min
电压 Voltage	AC三相380VAC 3-phase 380V	AC三相380VAC 3-phase 380V	AC三相380VAC 3-phase 380V	AC三相380VAC 3-phase 380V	AC三相380VAC 3-phase 380V	AC三相380VAC 3-phase 380V

选配
Optional
1、上下料取料机机械手2、上下料关节机器人3、自动检测平台4、进出料流水线5、自动堆料升降台6、滚轮快速清洁装置
1. Loading and unloading and reclaiming manipulators 2. Loading and unloading joint robots 3. Automatic detection platform
4. Inlet and outflow assembly line 5. Automatic stacking lifting platform 6. Roller quick cleaning device

更大、特殊尺寸、更快速度可按需求订制
Larger, special size, faster speed can be customized according to demand

液压高精度矫平机

Hydraulic high-precision leveler

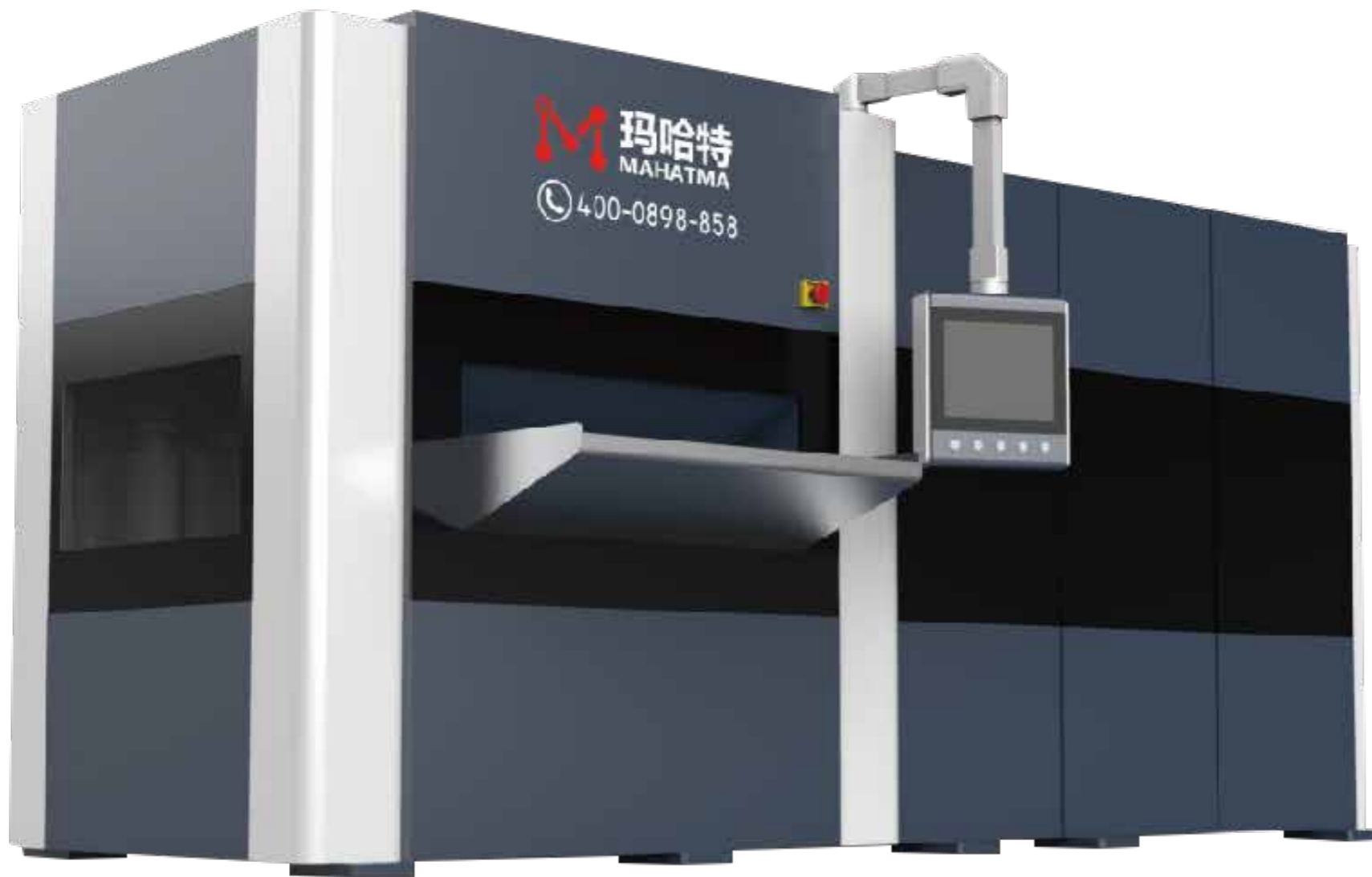

玛哈特液压精密矫平机使用德国进口液压系统和数控运算系统，强大的液压压力使上下矫正辊之间的间隙(机械式死限位)始终保持不变，将机器工作时的整体变形程度减少到最低，确保大批量零件矫正效果始终如一。

平行多辊，液压锁紧，密集支撑等技术，满足平面零件高精度的矫平要求。

主机结构采用的上下二块大梁，四角布置四根立柱拉杆的液压机主机结构！电子调速上下辊同步，超负荷自动停机功能！二梁四柱式左侧传动，设备右侧空间敞开，方便换辊及清洁，通过上梁的四个液压立柱拉杆锁紧上下矫平辊组之间的进口和出口辊隙，无论有没有板料零件通过机器，都保持进口和出口辊隙始终不变。

整机设计紧凑，占地面积小，一般不用做基础挖地坑。加工精度高，机器运转的时候非常安静，矫平范围覆盖广，矫平精度也远超机械行业标准，可以媲美进口矫平设备！成本低且反应快！可以在矫平机上直接快速和精确地采集和监控部件的平整度，精度可达微米。

Mahatma hydraulic precision leveler uses hydraulic system and NUMERICAL control operation system which are imported German, the strong hydraulic pressure makes the clearance between the upper and lower correction rollers (mechanical death limit) always remains unchanged, the overall deformation of the machine to reduce the minimum, to ensure that the correction effect of large numbers of parts is always consistent.

Parallel roller, hydraulic locking, intensive support and other technologies, to meet the requirements of high precision plane parts leveling.

The main machine structure adopts the upper and lower two girders, four corners of the layout of four column pull rod hydraulic machine structure! Electronic speed up and down roller synchronization, overload automatic stop function! Two beam four-column type left side drive, the right side of the equipment is open, convenient roll change and cleaning, through the upper beam four hydraulic column pull rod lock between the upper and lower leveling roller group of the inlet and outlet roll gap, regardless of whether there are sheet metal parts through the machine, keep the inlet and outlet roll gap is always unchanged.

Compact design, small footprint, generally do not need to do foundation digging pit. High processing accuracy, the machine is very quiet when working, the leveling range is wide, the leveling accuracy is far more than the mechanical industry standard, the same quality to imported leveling equipment! Low cost and fast response! The flatness of components can be collected and monitored directly, quickly and accurately, with an accuracy up to micron.

技术参数

Technical parameters

机型 Model	MHTY30	MHTY40	MHTY50	MHTY60	MHTY80
辊径 Roll diameter	30mm	40mm	50mm	60mm	80mm
额定宽度 Nominal width	400-2100mm	400-2100mm	400-2100mm	400-2100mm	400-2100mm
额定厚度 Rated thickness	0.5-3.0mm	0.6-4.0mm	0.8-5.0mm	1.0-8.0mm	2.0-10.0mm
最大厚度 Maximum thickness	5.0mm	8.0mm	10.0mm	15.0mm	20.0mm
最短工件 Shortest part	60mm	70mm	90mm	100mm	130mm
辊数 Number of rolls	23	23	23	21	19
适用对象 Suitable	薄板、中厚板、激光下料、机加工零件 Thin plate, thick plate, laser blanking, machined partst				
技术特色 Technical features	矫平精度高、液压补偿、防塌角 High leveling accuracy, hydraulic compensation, anti-collapse Anglet				
更大、特殊尺寸、更快速度可按需求订制 Larger, special size, faster speed can be customized according to demand					



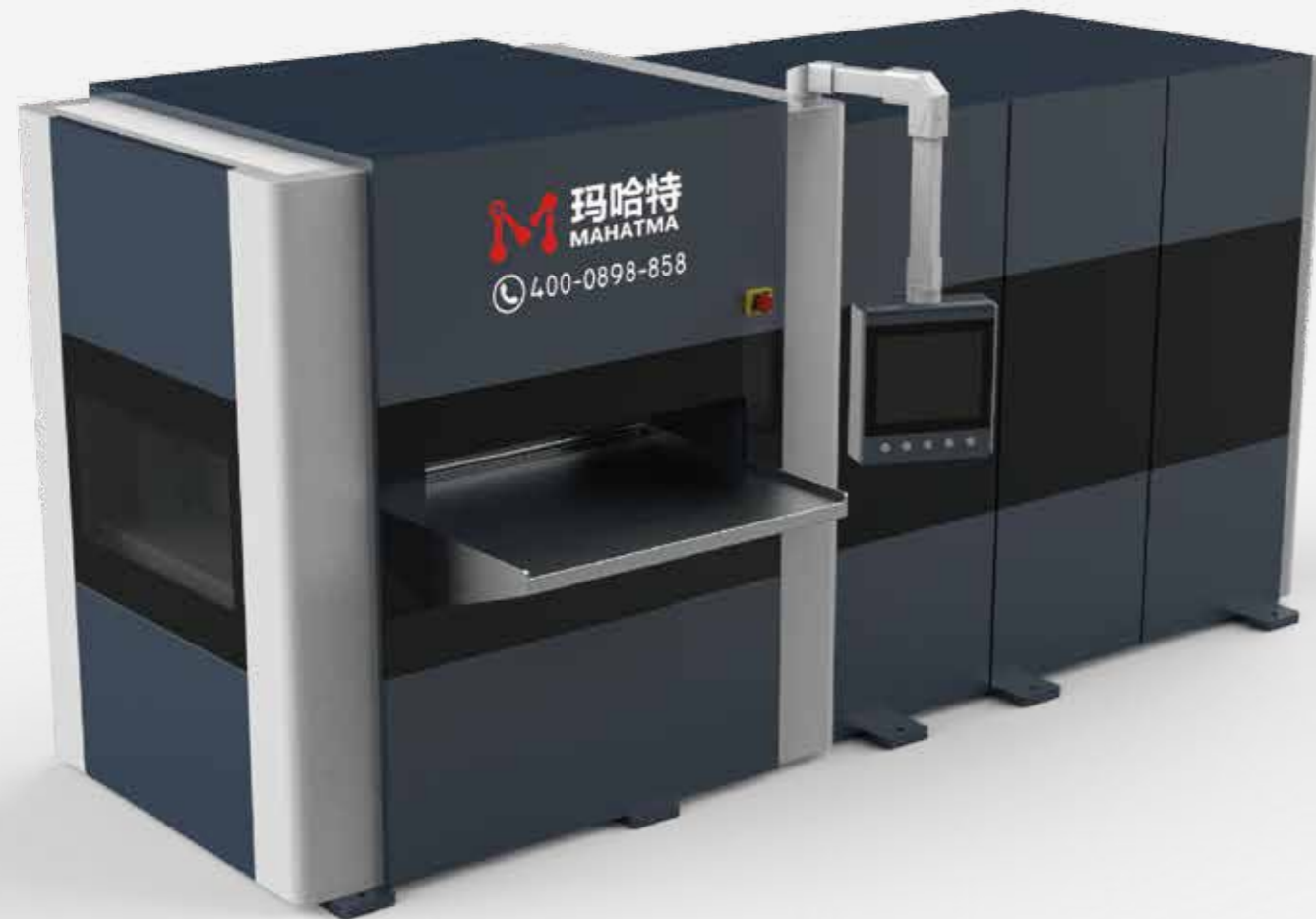

技术参数

Technical parameters

机型 Model	MHTY120	MHTY150	MHTY200	MHTY250	MHTY300
辊径 Roll diameter	120mm	150mm	200mm	250mm	300mm
额定宽度 Nominal width	400-2100mm	400-2100mm	600-2100mm	600-2600mm	600-2600mm
额定厚度 Rated thickness	4.0-20.0mm	6.0-30.0mm	8.0-40.0mm	10.0-50.0mm	12.0-60.0mm
最大厚度 Maximum thickness	30.0mm	36.0mm	48.0mm	60.0mm	80.0mm
最短工件 Shortest part	190mm	240mm	310mm	390mm	480mm
辊数 Number of rolls	19	19	15	15	15
适用对象 Suitable	厚板、超厚板、激光下料、机加工零件 Thick plate, super thick plate, laser cutting, machined parts				
技术特色 Technical features	矫平精度高、液压补偿、防塌角 High leveling accuracy, hydraulic compensation, anti-collapse Anglet				
	更大、特殊尺寸、更快速度可按需求订制 Larger, special size, faster speed can be customized according to demand				

四重式精密矫平机

FOUR-FOLD PRECISION LEVELING MACHINE



量产机型
SHS10-150-19A
Production models
SHS10-150-15A

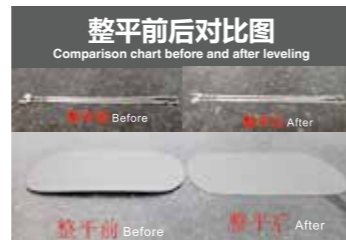

SHS10系列(厚度: 0.03-0.5mm)

SHS10 series(Thickness: 0.03-0.5mm)

机型 Model	SHS10-100-19A	SHS10-150-19A	SHS10-200-19A
宽度 Width	0-100mm	0-150mm	0-200mm
辊径 Roll diameter	10	10	10
额定厚度 Rated thickness	0.03-0.5mm	0.03-0.5mm	0.03-0.5mm
最大厚度 Maximum thickness	1.0mm	1.0mm	1.0mm
辊数 Number of rolls	19	19	19
最短工件 Shortest part	20	20	20
矫平速度 Leveling speed	0-15m/min	0-15m/min	0-15m/min
电压 Voltage	AC三相380VAC 3-phase 380V	AC三相380VAC 3-phase 380V	AC三相380VAC 3-phase 380V
选配 Optional	1、上下料取料机械手2、上下料关节机器人3、自动检测平台4、进出料流水线5、自动堆料升降台6、滚轮快速清洁装置 1. Loading and unloading and reclaiming manipulators 2. Loading and unloading joint robots 3. Automatic detection platform 4. Inlet and outflow assembly line 5. Automatic stacking lifting platform 6. Roller quick cleaning device		
更大、特殊尺寸、更快速度可按需求订制 Larger, special size, faster speed can be customized according to demand			

量产机型
SHS15-300-19A
Production models
SHS15-300-19A

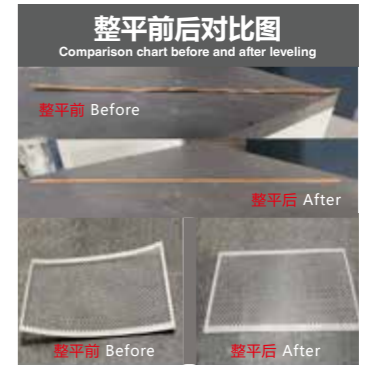

SHS15系列(厚度: 0.08-1.0mm)

SHS15 series(Thickness: 0.08-1.0mm)

机型 Model	SHS15-200-19A	SHS15-300-19A	SHS15-400-19A
宽度 Width	0-200mm	0-300mm	0-400mm
辊径 Roll diameter	15	15	15
额定厚度 Rated thickness	0.08-1.0mm	0.08-1.0mm	0.08-1.0mm
最大厚度 Maximum thickness	1.5mm	1.5mm	1.5mm
辊数 Number of rolls	19	19	19
最短工件 Shortest part	30	30	30
矫平速度 Leveling speed	0-15m/min	0-15m/min	0-15m/min
电压 Voltage	AC三相380VAC 3-phase 380V	AC三相380VAC 3-phase 380V	AC三相380VAC 3-phase 380V
选配 Optional	1、上下料取料机械手2、上下料关节机器人3、自动检测平台4、进出料流水线5、自动堆料升降台6、滚轮快速清洁装置 1. Loading and unloading and reclaiming manipulators 2. Loading and unloading joint robots 3. Automatic detection platform 4. Inlet and outflow assembly line 5. Automatic stacking lifting platform 6. Roller quick cleaning device		
更大、特殊尺寸、更快速度可按需求订制 Larger, special size, faster speed can be customized according to demand			

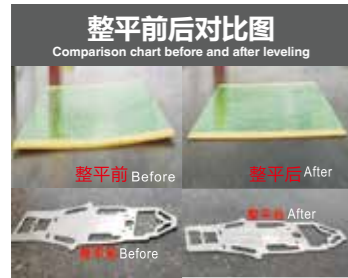

量产机型
SHS20-400-19A
Production models
SHS20-400-19A

SHS20系列(厚度: 0.2-1.5mm)

SHS20 series(Thickness: 0.2-1.5mm)

机型 Model	SHS20-400-19A	SHS20-600-19A	SHS20-800-19A
宽度 Width	0-400mm	0-600mm	0-800mm
辊径 Roll diameter	20	20	20
额定厚度 Rated thickness	0.2-1.5mm	0.2-1.5mm	0.2-1.5mm
最大厚度 Maximum thickness	2.0mm	2.0mm	2.0mm
辊数 Number of rolls	19	19	19
最短工件 Shortest part	40	40	40
矫平速度 Leveling speed	0-12m/min	0-12m/min	0-12m/min
电压 Voltage	AC三相380VAC 3-phase 380V	AC三相380VAC 3-phase 380V	AC三相380VAC 3-phase 380V

选配
Optional
1、上下料取料机机械手2、上下料关节机器人3、自动检测平台4、进出料流水线5、自动堆料升降台6、滚轮快速清洁装置
1. Loading and unloading and reclaiming manipulators 2. Loading and unloading joint robots 3. Automatic detection platform
4. Inlet and outflow assembly line 5. Automatic stacking lifting platform 6. Roller quick cleaning device

更大、特殊尺寸、更快速度可按需求订制
Larger, special size, faster speed can be customized according to demand



量产机型
SHS32-400-19A
Production models
SHS32-400-19A

SHS32系列(厚度: 0.5-2.0mm)

SHS32 series(Thickness: 0.5-2.0mm)

机型 Model	SHS32-400-19A	SHS32-600-19A	SHS32-800-19A	SHS32-1000-19A	SHS32-1300-19A
宽度 Width	0-400mm	0-600mm	0-800mm	0-1000mm	0-1300mm
辊径 Roll diameter	32	32	32	32	32
额定厚度 Rated thickness	0.5-2.0mm	0.5-2.0mm	0.5-2.0mm	0.5-2.0mm	0.5-2.0mm
最大厚度 Maximum thickness	3.0mm	3.0mm	3.0mm	3.0mm	3.0mm
辊数 Number of rolls	19	19	19	19	19
最短工件 Shortest part	60	60	60	60	60
矫平速度 Leveling speed	0-12m/min	0-12m/min	0-12m/min	0-12m/min	0-12m/min
电压 Voltage	AC三相380VAC 3-phase 380V	AC三相380VAC 3-phase 380V	AC三相380VAC 3-phase 380V	AC三相380VAC 3-phase 380V	AC三相380VAC 3-phase 380V

选配
Optional
1、上下料取料机机械手2、上下料关节机器人3、自动检测平台4、进出料流水线5、自动堆料升降台6、滚轮快速清洁装置
1. Loading and unloading and reclaiming manipulators 2. Loading and unloading joint robots 3. Automatic detection platform
4. Inlet and outflow assembly line 5. Automatic stacking lifting platform 6. Roller quick cleaning device

更大、特殊尺寸、更快速度可按需求订制
Larger, special size, faster speed can be customized according to demand

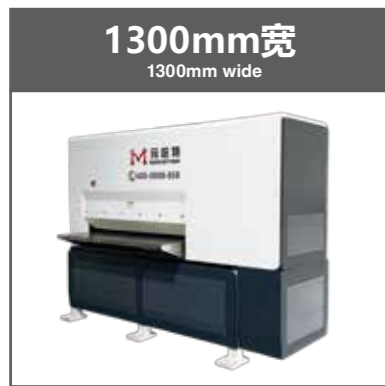

量产机型
SHS42-400-19A
Production models
SHS42-400-19A

SHS42系列(厚度: 0.4-3.0mm)

SHS42 series(Thickness: 0.4-3.0mm)

机型 Model	SHS42-400-19A	SHS42-600-19A	SHS42-800-19A	SHS42-1000-19A	SHS42-1300-19A
宽度 Width	0-400mm	0-600mm	0-800mm	0-1000mm	0-1300mm
辊径 Roll diameter	42	42	42	42	42
额定厚度 Rated thickness	0.4-3.0mm	0.4-3.0mm	0.4-3.0mm	0.4-3.0mm	0.4-3.0mm
最大厚度 Maximum thickness	5.0mm	5.0mm	5.0mm	5.0mm	5.0mm
辊数 Number of rolls	19	19	19	19	19
最短工件 Shortest part	70	70	70	70	70
矫平速度 Leveling speed	0-12m/min	0-12m/min	0-12m/min	0-12m/min	0-12m/min
电压 Voltage	AC三相380VAC 3-phase 380V	AC三相380VAC 3-phase 380V	AC三相380VAC 3-phase 380V	AC三相380VAC 3-phase 380V	AC三相380VAC 3-phase 380V
选配 Optional	1、上下料取料机械手2、上下料关节机器人3、自动检测平台4、进出料流水线5、自动堆料升降台6、滚轮快速清洁装置 1. Loading and unloading and reclaiming manipulators 2. Loading and unloading joint robots 3. Automatic detection platform 4. Inlet and outflow assembly line 5. Automatic stacking lifting platform 6. Roller quick cleaning device				
更大、特殊尺寸、更快速度可按需求订制 Larger, special size, faster speed can be customized according to demand					

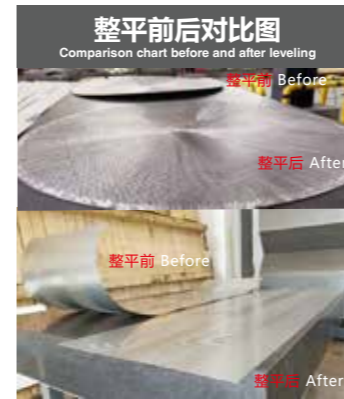

量产机型
SHS50-400-15A
Production models
SHS50-400-15A

SHS50系列(厚度: 0.8-3.5mm)

SHS50 series (Thickness: 0.8-3.5mm)

机型 Model	SHS50-400-15A	SHS50-600-15A	SHS50-800-15A	SHS50-1000-15A	SHS50-1300-15A	SHS50-1600-15A
宽度 Width	0-400mm	0-600mm	0-800mm	0-1000mm	0-1300mm	0-1600mm
辊径 Roll diameter	50	50	50	50	50	50
额定厚度 Rated thickness	0.8-3.5mm	0.8-3.5mm	0.8-3.5mm	0.8-3.5mm	0.8-3.5mm	0.8-3.5mm
最大厚度 Maximum thickness	6.0mm	6.0mm	6.0mm	6.0mm	6.0mm	6.0mm
辊数 Number of rolls	15	15	15	15	15	15
最短工件 Shortest part	90	90	90	90	90	90
矫平速度 Leveling speed	0-12m/min	0-12m/min	0-12m/min	0-12m/min	0-12m/min	0-12m/min
电压 Voltage	AC三相380VAC 3-phase 380V	AC三相380VAC 3-phase 380V	AC三相380VAC 3-phase 380V	AC三相380VAC 3-phase 380V	AC三相380VAC 3-phase 380V	AC三相380VAC 3-phase 380V
选配 Optional	1、上下料取料机械手2、上下料关节机器人3、自动检测平台4、进出料流水线5、自动堆料升降台6、滚轮快速清洁装置 1. Loading and unloading and reclaiming manipulators 2. Loading and unloading joint robots 3. Automatic detection platform 4. Inlet and outflow assembly line 5. Automatic stacking lifting platform 6. Roller quick cleaning device					
更大、特殊尺寸、更快速度可按需求订制 Larger, special size, faster speed can be customized according to demand						

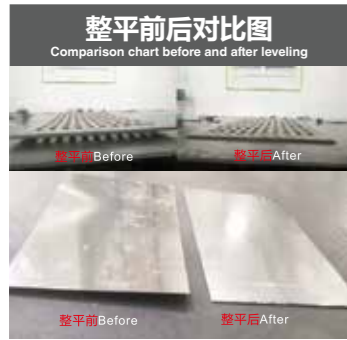

量产机型
SHS60-600-15A
Production models
SHS60-600-15A

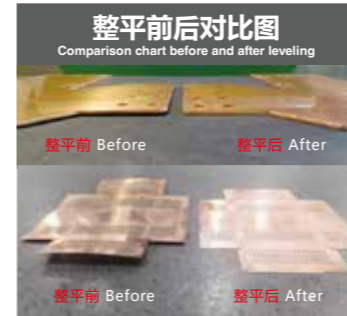

量产机型
SHS80-600-15A
Production models
SHS80-600-15A

SHS60系列(厚度: 1.0-6.0mm)

SHS60 series(Thickness: 1.0-6.0mm)

机型 Model	SHS60-400-15A	SHS60-600-15A	SHS60-800-15A	SHS60-1000-15A	SHS60-1300-15A	SHS60-1600-15A
宽度 Width	0-400mm	0-600mm	0-800mm	0-1000mm	0-1300mm	0-1600mm
辊径 Roll diameter	60	60	60	60	60	60
额定厚度 Rated thickness	1.0-6.0mm	1.0-6.0mm	1.0-6.0mm	1.0-6.0mm	1.0-6.0mm	1.0-6.0mm
最大厚度 Maximum thickness	10.0mm	10.0mm	10.0mm	10.0mm	10.0mm	10.0mm
辊数 Number of rolls	15	15	15	15	15	15
最短工件 Shortest part	100	100	100	100	100	100
矫平速度 Leveling speed	0-10m/min	0-10m/min	0-10m/min	0-10m/min	0-10m/min	0-10m/min
电压 Voltage	AC三相380VAC 3-phase 380V	AC三相380VAC 3-phase 380V	AC三相380VAC 3-phase 380V	AC三相380VAC 3-phase 380V	AC三相380VAC 3-phase 380V	AC三相380VAC 3-phase 380V

选配
Optional
1、上下料取料机械手2、上下料关节机器人3、自动检测平台4、进出料流水线5、自动堆料升降台6、滚轮快速清洁装置
1. Loading and unloading and reclaiming manipulators 2. Loading and unloading joint robots 3. Automatic detection platform 4. Inlet and outflow assembly line 5. Automatic stacking lifting platform 6. Roller quick cleaning device

更大、特殊尺寸、更快速度可按需求订制
Larger, special size, faster speed can be customized according to demand

SHS80系列(厚度: 2.0-8.0mm)

SHS80 series(Thickness: 2.0-8.0mm)

机型 Model	SHS80-400-15A	SHS80-600-15A	SHS80-800-15A	SHS80-1000-15A	SHS80-1300-15A	SHS80-1600-15A	SHS80-2100-15A
宽度 Width	0-400mm	0-600mm	0-800mm	0-1000mm	0-1300mm	0-1600mm	0-2100mm
辊径 Roll diameter	80	80	80	80	80	80	80
额定厚度 Rated thickness	2.0-8.0mm	2.0-8.0mm	2.0-8.0mm	2.0-8.0mm	2.0-8.0mm	2.0-8.0mm	2.0-8.0mm
最大厚度 Maximum thickness	14.0mm	14.0mm	14.0mm	14.0mm	14.0mm	14.0mm	14.0mm
辊数 Number of rolls	15	15	15	15	15	15	15
最短工件 Shortest part	130	130	130	130	130	130	130
矫平速度 Leveling speed	0-10m/min	0-10m/min	0-10m/min	0-10m/min	0-10m/min	0-10m/min	0-10m/min
电压 Voltage	AC三相380VAC 3-phase 380V	AC三相380VAC 3-phase 380V	AC三相380VAC 3-phase 380V	AC三相380VAC 3-phase 380V	AC三相380VAC 3-phase 380V	AC三相380VAC 3-phase 380V	AC三相380VAC 3-phase 380V

选配
Optional
1、上下料取料机械手2、上下料关节机器人3、自动检测平台4、进出料流水线5、自动堆料升降台6、滚轮快速清洁装置
1. Loading and unloading and reclaiming manipulators 2. Loading and unloading joint robots 3. Automatic detection platform 4. Inlet and outflow assembly line 5. Automatic stacking lifting platform 6. Roller quick cleaning device

更大、特殊尺寸、更快速度可按需求订制
Larger, special size, faster speed can be customized according to demand

普通矫平机

GENERAL LEVELER



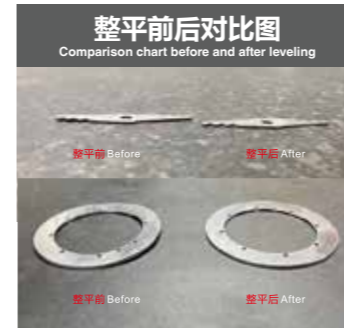
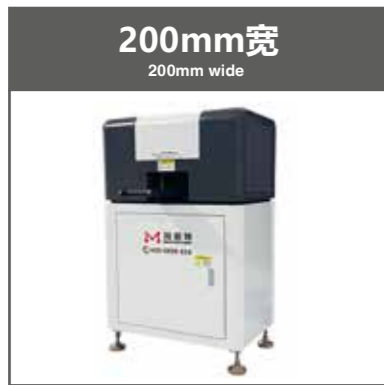

STS42系列(厚度: 0.4-3.0mm)

STS42 series(Thickness: 0.4-3.0mm)

机型 Model	STS42-200-19	STS42-300-19	STS42-400-19	STS42-600-19
宽度 Width	0-200mm	0-300mm	0-400mm	0-600mm
辊径 Roll diameter	42	42	42	42
额定厚度 Rated thickness	0.4-3.0mm	0.4-3.0mm	0.4-3.0mm	0.4-3.0mm
辊数 Number of rolls	19	19	19	19
最短工件 Shortest part	70	70	70	70
矫平速度 Leveling speed	0-15m/min	0-15m/min	0-15m/min	0-15m/min
电压 Voltage	AC三相380VAC 3-phase 380V	AC三相380VAC 3-phase 380V	AC三相380VAC 3-phase 380V	AC三相380VAC 3-phase 380V
选配 Optional	1、上下料取料机械手2、上下料关节机器人3、自动检测平台4、进出料流水线5、自动堆料升降台6、滚轮快速清洁装置 1. Loading and unloading and reclaiming manipulators 2. Loading and unloading joint robots 3. Automatic detection platform 4. Inlet and outflow assembly line 5. Automatic stacking lifting platform 6. Roller quick cleaning device			
更大、特殊尺寸、更快速度可按需求订制 Larger, special size, faster speed can be customized according to demand				

STS70系列(厚度: 0.8-6.0mm)

STS70series(Thickness: 0.8-6.0mm)

机型 Model	STS70-200-13	STS70-400-13	STS70-600-13	STS70-800-13	STS70-1000-13	STS70-1300-13	STS70-1600-13
宽度 Width	0-200mm	0-400mm	0-600mm	0-800mm	0-1000mm	0-1300mm	0-1600mm
辊径 Roll diameter	70	70	70	70	70	70	70
额定厚度 Rated thickness	0.8-6.0mm	0.8-6.0mm	0.8-6.0mm	0.8-6.0mm	0.8-6.0mm	0.8-6.0mm	0.8-6.0mm
辊数 Number of rolls	13	13	13	13	13	13	13
最短工件 Shortest part	120	120	120	120	120	120	120
矫平速度 Leveling speed	0-15m/min	0-15m/min	0-15m/min	0-15m/min	0-15m/min	0-15m/min	0-15m/min
电压 Voltage	AC三相380VAC 3-phase 380V	AC三相380VAC 3-phase 380V	AC三相380VAC 3-phase 380V	AC三相380VAC 3-phase 380V	AC三相380VAC 3-phase 380V	AC三相380VAC 3-phase 380V	AC三相380VAC 3-phase 380V
选配 Optional	1、上下料取料机械手2、上下料关节机器人3、自动检测平台4、进出料流水线5、自动堆料升降台6、滚轮快速清洁装置 1. Loading and unloading and reclaiming manipulators 2. Loading and unloading joint robots 3. Automatic detection platform 4. Inlet and outflow assembly line 5. Automatic stacking lifting platform 6. Roller quick cleaning device						
更大、特殊尺寸、更快速度可按需求订制 Larger, special size, faster speed can be customized according to demand							

量产机型

STS90-600-13

Production models
STS90-600-13

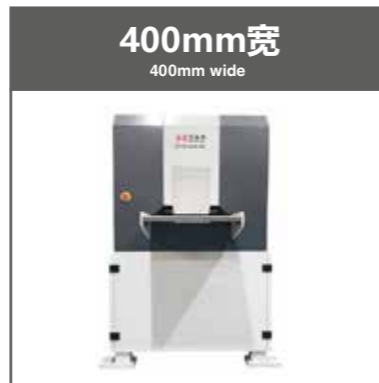
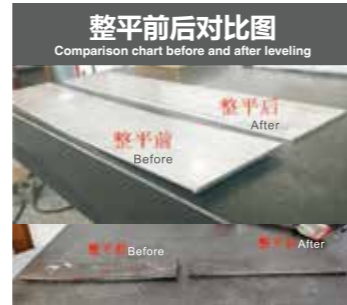

STS90系列(厚度: 3.0-8.0mm)

STS90 serie(Thickness: 3.0-8.0mm)

机型 Model	STS90-400-13	STS90-600-13	STS90-800-13	STS90-1300-13	STS90-1600-13
宽度 Width	0-400mm	0-600mm	0-800mm	0-1300mm	0-1600mm
辊径 Roll diameter	90	90	90	90	90
额定厚度 Rated thickness	3.0-8.0mm	3.0-8.0mm	3.0-8.0mm	3.0-8.0mm	3.0-8.0mm
辊数 Number of rolls	13	13	13	13	13
最短工件 Shortest part	150	150	150	150	150
矫平速度 Leveling speed	0-12m/min	0-12m/min	0-12m/min	0-12m/min	0-12m/min
电压 Voltage	AC三相380VAC 3-phase 380V	AC三相380VAC 3-phase 380V	AC三相380VAC 3-phase 380V	AC三相380VAC 3-phase 380V	AC三相380VAC 3-phase 380V
选配 Optional	1、上下料取料机械手2、上下料关节机器人3、自动检测平台4、进出料流水线5、自动堆料升降台6、滚轮快速清洁装置 1. Loading and unloading and reclaiming manipulators 2. Loading and unloading joint robots 3. Automatic detection platform 4. Inlet and outflow assembly line 5. Automatic stacking lifting platform 6. Roller quick cleaning device				
更大、特殊尺寸、更快速度可按需求订制 Larger, special size, faster speed can be customized according to demand					

量产机型

STS120-600-13
STS120-1300-13

Production models
STS120-600-13
STS120-1300-13

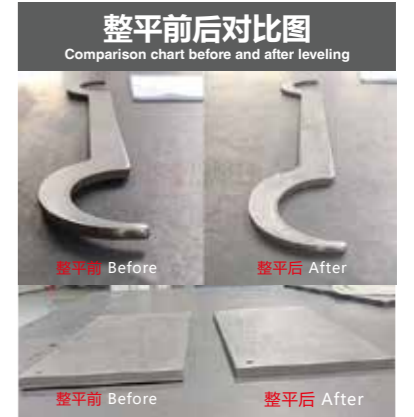

STS120系列(厚度: 4.0-12.0mm)

STS120 serie(Thickness: 4.0-12.0mm)

机型 Model	STS120-400-13	STS120-600-13	STS120-1000-13	STS120-1300-13	STS120-1600-13	STS120-2100-13
宽度 Width	0-400mm	0-600mm	0-1000mm	0-1300mm	0-1600mm	0-2100mm
辊径 Roll diameter	120	120	120	120	120	120
额定厚度 Rated thickness	4.0-12.0mm	4.0-12.0mm	4.0-12.0mm	4.0-12.0mm	4.0-12.0mm	4.0-12.0mm
辊数 Number of rolls	13	13	13	13	13	13
最短工件 Shortest part	190	190	190	190	190	190
矫平速度 Leveling speed	0-12m/min	0-12m/min	0-12m/min	0-12m/min	0-12m/min	0-12m/min
电压 Voltage	AC三相380VAC 3-phase 380V	AC三相380VAC 3-phase 380V	AC三相380VAC 3-phase 380V	AC三相380VAC 3-phase 380V	AC三相380VAC 3-phase 380V	AC三相380VAC 3-phase 380V
选配 Optional	1、上下料取料机械手2、上下料关节机器人3、自动检测平台4、进出料流水线5、自动堆料升降台6、滚轮快速清洁装置 1. Loading and unloading and reclaiming manipulators 2. Loading and unloading joint robots 3. Automatic detection platform 4. Inlet and outflow assembly line 5. Automatic stacking lifting platform 6. Roller quick cleaning device					
更大、特殊尺寸、更快速度可按需求订制 Larger, special size, faster speed can be customized according to demand						

量产机型
STS150-600-13
Production models
STS150-600-13

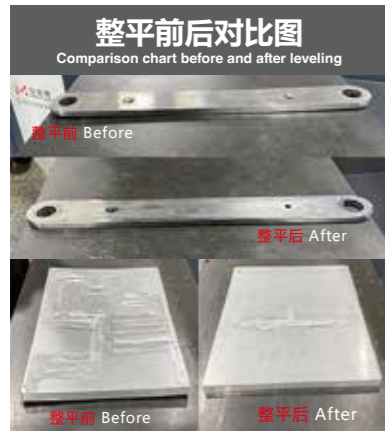

STS150系列(厚度: 6.0-18.0mm)

STS150 serie(Thickness: 6.0-18.0mm)

机型 Model	STS150-450-13	STS150-600-13	STS150-1000-13	STS150-1300-13	STS150-1600-13	STS150-2100-13
宽度 Width	0-450mm	0-600mm	0-1000mm	0-1300mm	0-1600mm	0-2100mm
辊径 Roll diameter	150	150	150	150	150	150
额定厚度 Rated thickness	6.0-18.0mm	6.0-18.0mm	6.0-18.0mm	6.0-18.0mm	6.0-18.0mm	6.0-18.0mm
辊数 Number of rolls	13	13	13	13	13	13
最短工件 Shortest part	240	240	240	240	240	240
矫平速度 Leveling speed	0-12m/min	0-12m/min	0-12m/min	0-12m/min	0-12m/min	0-12m/min
电压 Voltage	AC三相380VAC 3-phase 380V	AC三相380VAC 3-phase 380V	AC三相380VAC 3-phase 380V	AC三相380VAC 3-phase 380V	AC三相380VAC 3-phase 380V	AC三相380VAC 3-phase 380V
选配 Optional	1、上下料取料机2、上下料关节机器人3、自动检测平台4、进出料流水线5、自动堆料升降台6、滚轮快速清洁装置 1. Loading and unloading and reclaiming manipulators 2. Loading and unloading joint robots 3. Automatic detection platform 4. Inlet and outflow assembly line 5. Automatic stacking lifting platform 6. Roller quick cleaning device					
更大、特殊尺寸、更快速度可按需求订制 Larger, special size, faster speed can be customized according to demand						

量产机型
STS200-600-13
Production models
STS200-600-13



STS200系列(厚度: 8.0-25.0mm)

STS200 serie(Thickness: 8.0-25.0mm)

机型 Model	STS200-450-13	STS200-600-13	STS200-1000-13	STS200-1300-13	STS200-1600-13	STS200-2100-13
宽度 Width	0-450mm	0-600mm	0-1000mm	0-1300mm	0-1600mm	0-2100mm
辊径 Roll diameter	200	200	200	200	200	200
额定厚度 Rated thickness	8.0-25.0mm	8.0-25.0mm	8.0-25.0mm	8.0-25.0mm	8.0-25.0mm	8.0-25.0mm
辊数 Number of rolls	13	13	13	13	13	13
最短工件 Shortest part	310	310	310	310	310	310
矫平速度 Leveling speed	0-12m/min	0-12m/min	0-12m/min	0-12m/min	0-12m/min	0-12m/min
电压 Voltage	AC三相380VAC 3-phase 380V	AC三相380VAC 3-phase 380V	AC三相380VAC 3-phase 380V	AC三相380VAC 3-phase 380V	AC三相380VAC 3-phase 380V	AC三相380VAC 3-phase 380V
选配 Optional	1、上下料取料机2、上下料关节机器人3、自动检测平台4、进出料流水线5、自动堆料升降台6、滚轮快速清洁装置 1. Loading and unloading and reclaiming manipulators 2. Loading and unloading joint robots 3. Automatic detection platform 4. Inlet and outflow assembly line 5. Automatic stacking lifting platform 6. Roller quick cleaning device					
更大、特殊尺寸、更快速度可按需求订制 Larger, special size, faster speed can be customized according to demand						

全自动高精密整平剪切线

Fully automatic high precision leveling shearing line

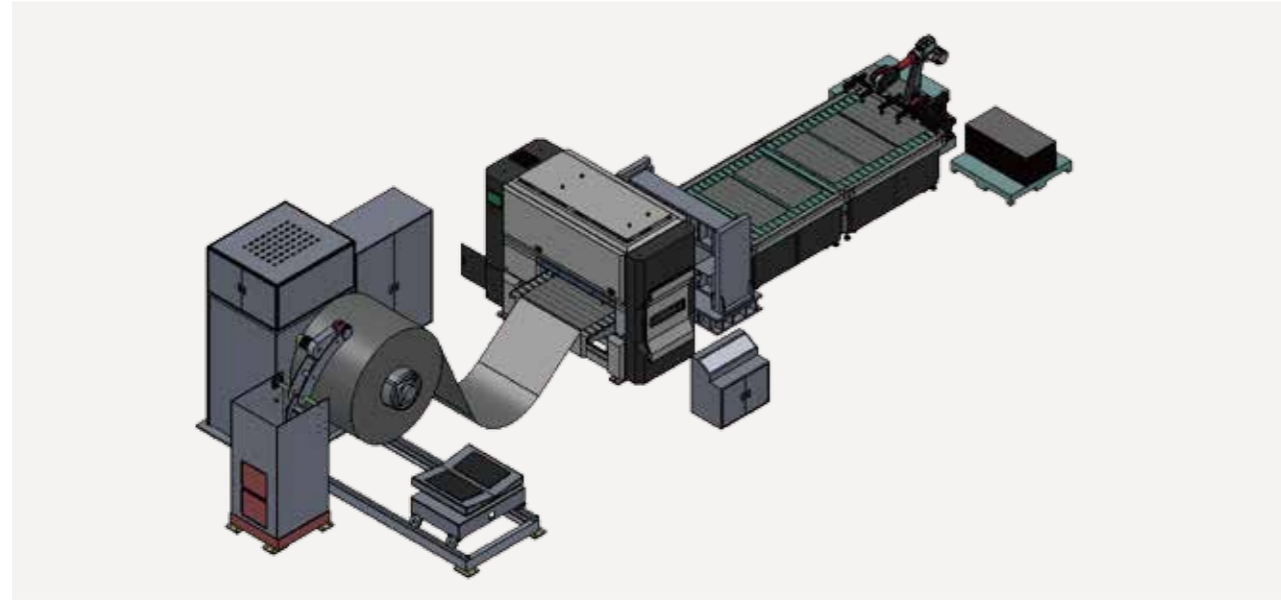

(1)开卷+自动高精密矫平进料+自动剪切+全自动进出料流水线+关节机器人

(1) Uncoiling + automatic high-precision leveling feeding + automatic cutting + automatic feeding and discharging line + joint robot

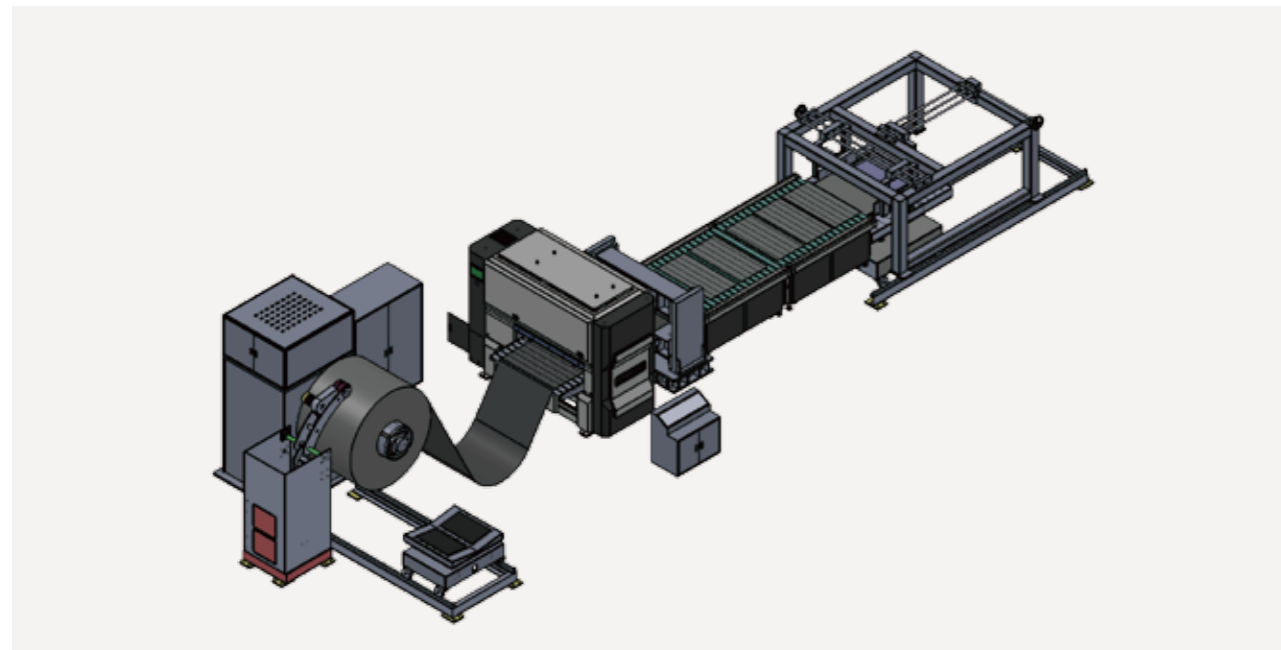

(2)开卷+自动高精密矫平进料+自动剪切+全自动进出料流水线+关节机械手

(2) Uncoiling + automatic high-precision leveling feeding + automatic cutting + automatic feeding and discharging line + joint manipulator

全自动高精密激光生产线

Automatic high precision laser production line



(1)开卷+全自动高精密矫平(送料)+覆膜+激光切割+自动落料(可选关节机器人/关节机械手)

(1) Uncoiling + automatic high precision leveling (feeding) + laminating + laser cutting + automatic blanking (optional joint robot/joint manipulator)



(2)片料上料+自动送料+全自动高精密矫平+覆膜+激光切割+自动下料(可选关节机器人/关节机械手)

(2) Sheet feeding + automatic feeding + automatic high precision leveling + laminating + laser cutting + automatic feeding (optional joint robot/joint manipulator)

整平前后对比图展示

Comparison chart before and after leveling

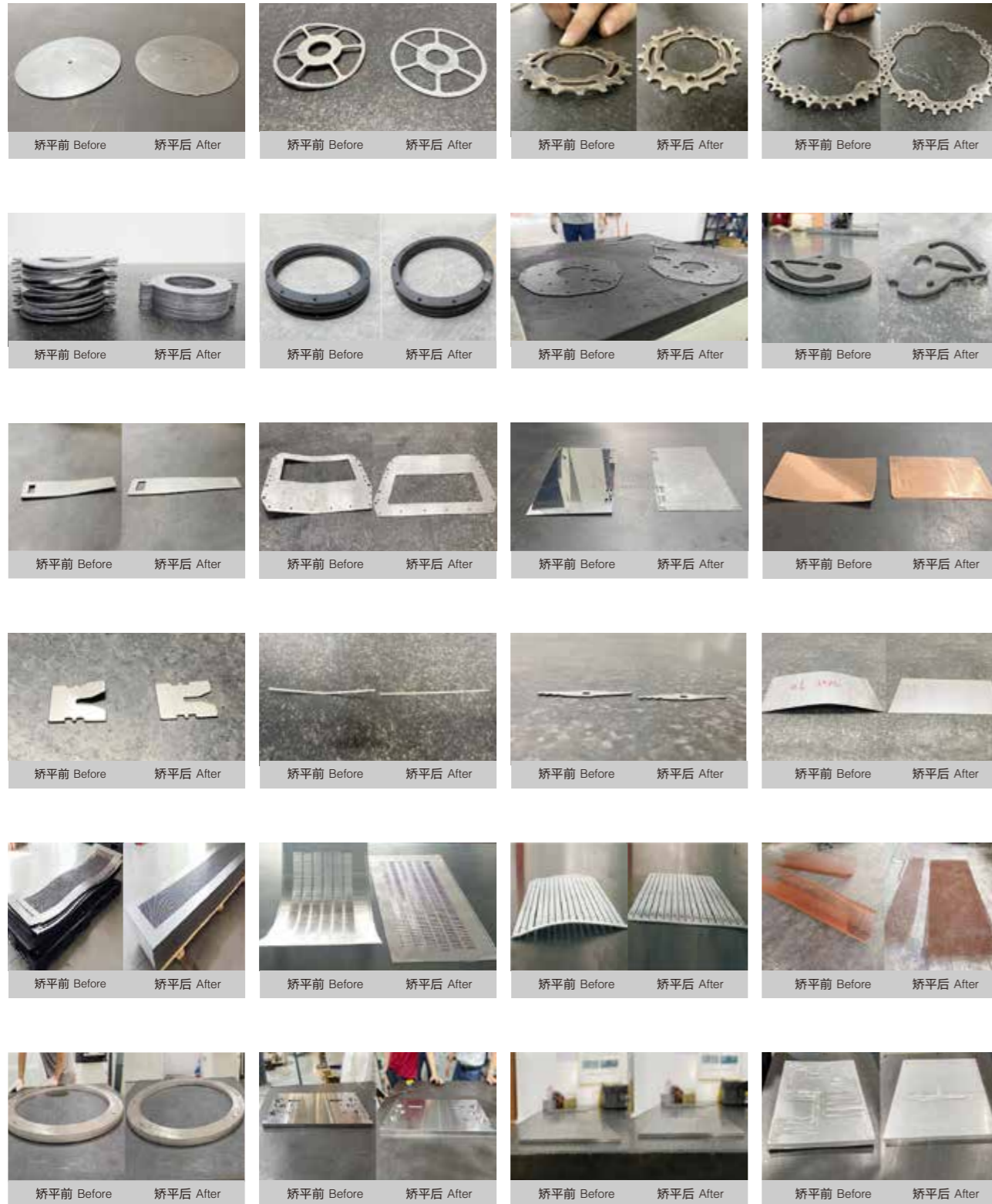

部分行业整平样品展示

Partial industry leveling sample display

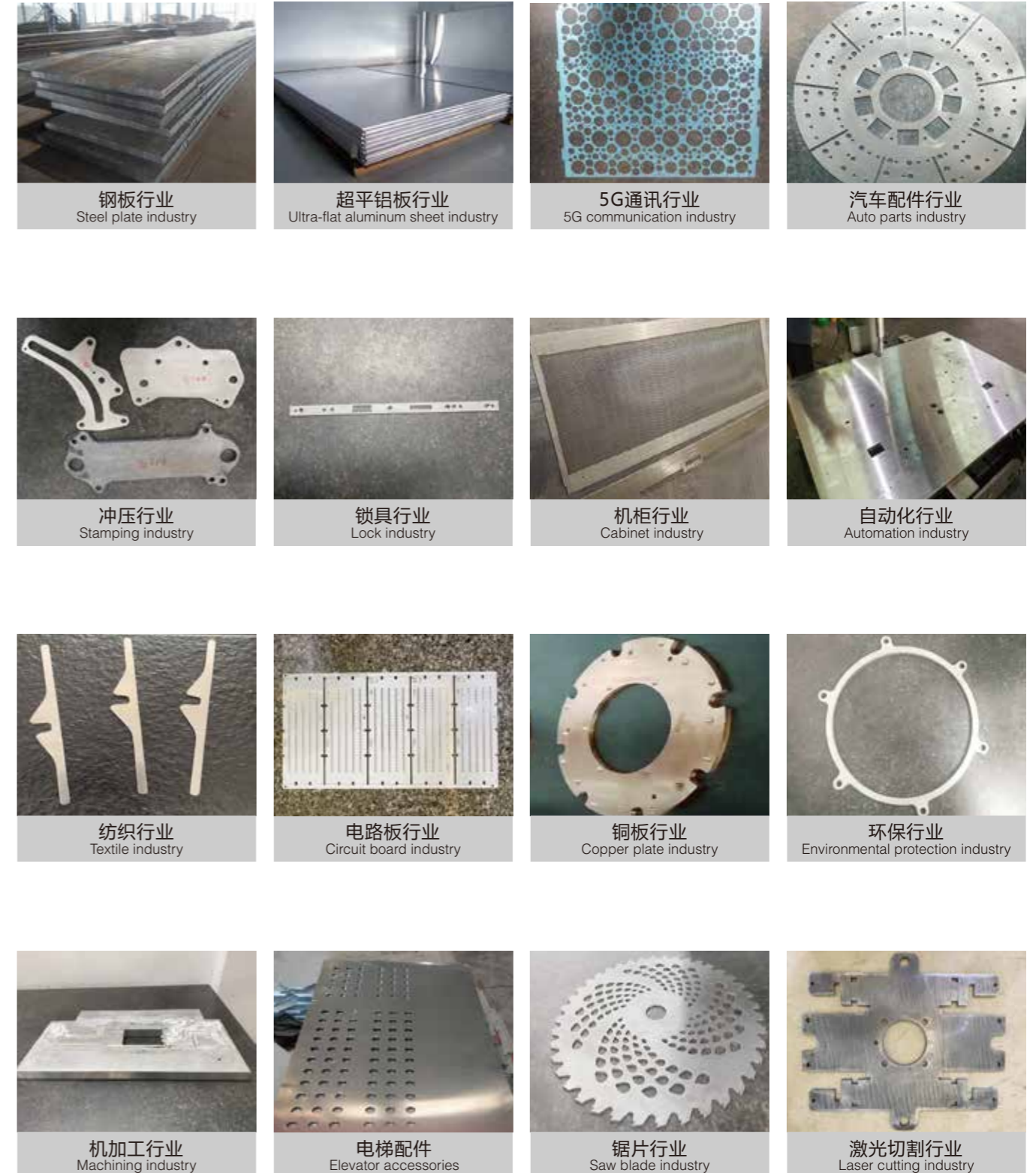

· 售前服务

· Pre-sale service

根据客户需求，从客户角度出发为客户提供矫平机准确的技术参数信息，为客户量身定制产品，回答客户提出的所有问题；从技术可行性角度出发，协助客户做好工程规划和系统需求分析，使得我们的产品能够最大限度的满足用户需要。同时提供免费打样，以及我们所拥有的样品平整基地以便客户实地考察、现场参观。从而使客户更直接地作出准确的经营决策，开拓新的市场。

According to customer needs, from the customer's point to provide customers with accurate technical parameters of the leveler, customize products for customers, answer all the questions raised by customers; From the technical feasibility point, to assist customers to do a good job in engineering planning and system requirements analysis, so that our products can maximize to meet the needs of users. At the same time to provide free proofing, and we have the sample leveling base for customers to visit the site. So that customers more directly to make accurate business decisions, open up new markets.



从客户出发



为客户着想



对客户负责



让客户满意

· 现场培训

· On-the-job training

在双方签订买卖合同后,根据客户的具体要求,我公司免费为用户进行调试及调试后的现场培训。最终让客户负责矫平机设备的相关技术人员,完全掌握了我公司矫平机设备技术特点、操作程序、保养常识后,我们的培训人员才能撤离。具体内容如下:

After the signing of the sales contract, according to the specific requirements of the customer, our company will provide consumers with free debugging and on-site training after debugging. Finally let the customer responsible for the leveler equipment related technical personnel, fully master the technical characteristics of our company leveler equipment, operating procedures, maintenance of common sense, our trainer can be evacuated. The details are as follows:



矫平机
原理及解释



矫平机
设备系统组件



矫平机
的操作



矫平机
的保养



常见故障
的解决方案

· 售后服务

· After-sales service

- 1、对销售合同中要求进行用户现场安装调试的，在规定的时间内，组织人员对产品进行安装调试及对用户操作人员进行培训。
- 2、根据合同及技术协议的要求，对保修期内，因产品的制造、装配及材料等质量问题造成各类故障或零件损坏，无偿为用户维修或更换相应零配件。
- 3、定期组织人员对重点销售区域和重点客户进行走访，了解产品的使用情况，征求用户对产品在设计，装配，工艺等方面的意见。
- 4、保证向客户提供产品是原厂全新产品；并针对产品，保修期为一年；在保修期内，如供方产品在正常使用的情况下出现非人为因素之机械故障、自然损坏等情形，由我司负责免费维修或更换；如客户因人为保修失当和不可抗力因素所造成的故障需酌收成本费用；质保期内，设备如有故障，我司接到客户通知后，先进行电话沟通解决，若电话沟通解决不了，则48小时内派人到现场排除故障。

1. Organize the personnel to install and debug the products and train the user operators within the specified time as required by the sales contract.
2. According to the requirements of the contract and technical agreement, we will repair or replace the corresponding spare parts for users free of charge for all kinds of faults or parts damage caused by the quality problems such as product manufacturing, assembly and materials during the warranty period.
3. Regularly organize personnel to visit key sales areas and key customers, understand the use of products, and solicit users' opinions on product design, assembly, process, etc.
4. Ensure that the products provided to customers are brand-new products of the original factory; And for products, the warranty period is one year; During the warranty period, if the supplier's products have non-human mechanical failure and natural damage under normal use, our company shall be responsible for free maintenance or replacement; If the customer's fault is caused by improper human warranty and force majeure, the cost shall be charged; During the warranty period, if there is a fault in the equipment, our company will first communicate by telephone after receiving the customer's notice. If the problem cannot be solved by telephone communication, we will send someone to the site to eliminate the fault within 48 hours.

